

# WRM-10

Transformer Resistance Meter



**Vanguard Instruments Company**  
[www.vanguard-instruments.com](http://www.vanguard-instruments.com)



# Accurately



## WRM-10™

### Quick and Accurate Measurements

The WRM-10 is designed to accurately measure the winding resistance of highly inductive power transformers. The unit's dual resistance-reading input channels can measure two winding resistances simultaneously, and four-wire (Kelvin) connections provide high accuracy and require no lead compensation. The WRM-10 provides stable resistance readings of very large transformers by utilizing a 36Vdc power supply capable of outputting up to 10 Amperes.

The resistance reading of a 100MVA transformer can be achieved in 5 minutes or less. The unit's power supply is cooled by heavy-duty fans designed for continuous operation.

Since the WRM-10 can accurately measure resistances ranging from 1 micro-ohm to 2,000 ohms, it can also be used to measure EHV circuit-breaker contact resistance, motor winding resistance, or any low resistance. In addition to measuring the resistance value, the WRM-10 also checks the "make-before-break" tap-switching sequences of voltage regulators and load tap changers.

The WRM-10 is furnished with three 50-foot test cables. Each test cable lead is terminated with a quick-disconnect test clip.

### Built-in Safety Features

At the end of each test, the WRM-10 automatically dissipates the stored energy in the transformer. This discharge circuit will continue to work even if the supply voltage is lost. For added safety, the unit's power supply is thermally protected from over-load damage.

### User Interface

The WRM-10 features a back-lit LCD screen (16 characters by 2 lines) that is viewable in both bright sunlight and low-light levels. A "turn-and-push" knob is used to control the unit. A built-in RS-232C interface port is provided for diagnostic testing and firmware upgrades.

## SPECIFICATIONS

<b>TYPE</b>	Portable transformer winding resistance meter
<b>PHYSICAL SPECIFICATIONS</b>	16.8"W x 12.6"H x 10.6"D (42.6 cm x 32.0 cm x 27 cm); Weight: 27 lbs (12.2 kg)
<b>INPUT POWER</b>	100 – 120 Vac or 200-240 Vac (factory pre-set), 50/60 Hz
<b>RESISTANCE READING RANGE</b>	1 micro-ohm – 2,000 ohms
<b>ACCURACY</b>	1 – 19,999 micro-ohms: ±0.5% reading, ±1 count; 20 – 999 milli-ohms: ±1% reading, ±1 count; 1 – 2,000 ohms: ±1.5% reading, ±1 count
<b>TEST VOLTAGE</b>	36 Vdc max
<b>TEST CURRENT RANGE</b>	Auto range, 10 Amperes max
<b>DISPLAY</b>	Back-lit LCD Screen (16 characters by 2 lines); viewable in bright sunlight and low-light levels
<b>CONTROL</b>	Single "turn-and-push" knob
<b>COMPUTER INTERFACE</b>	RS-232C port (19,200 baud) used for factory calibration and diagnostics
<b>SAFETY</b>	Designed to meet IEC61010 (1995), UL61010A-1, CSA-C22.2 standards
<b>ENVIRONMENT</b>	Operating: -10°C to 50° C (15°F to +122° F); Storage: -30° C to 70° C (-22°F to +158° F)
<b>HUMIDITY</b>	90% RH @ 40°C (104°F) non-condensing
<b>ALTITUDE</b>	2,000m (6,562 ft) to full safety specifications
<b>CABLES</b>	Three 50-foot test cables, ground cable, power cord and cable bag
<b>OPTIONS</b>	Transportation case
<b>WARRANTY</b>	One year on parts and labor

Note: The above specifications are valid at nominal voltage and ambient temperature of +25°C (+77°F). Specifications are subject to change without notice.

# Lightweight Winding Resistance Meter

# Measure Winding Resistances of Highly Inductive Power Transformers

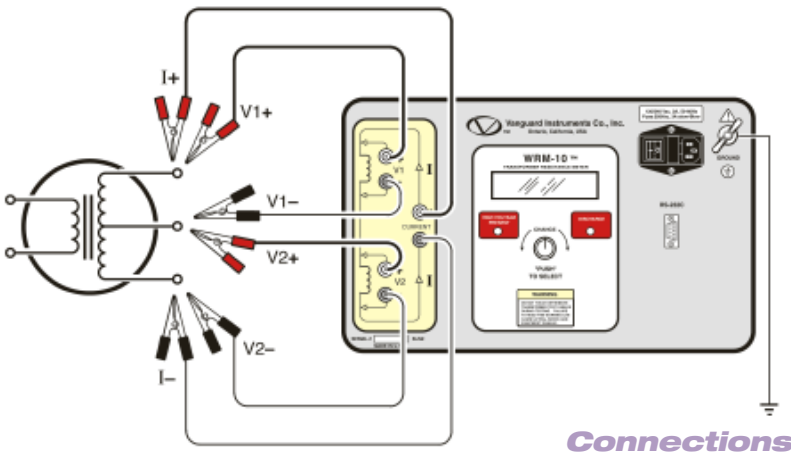
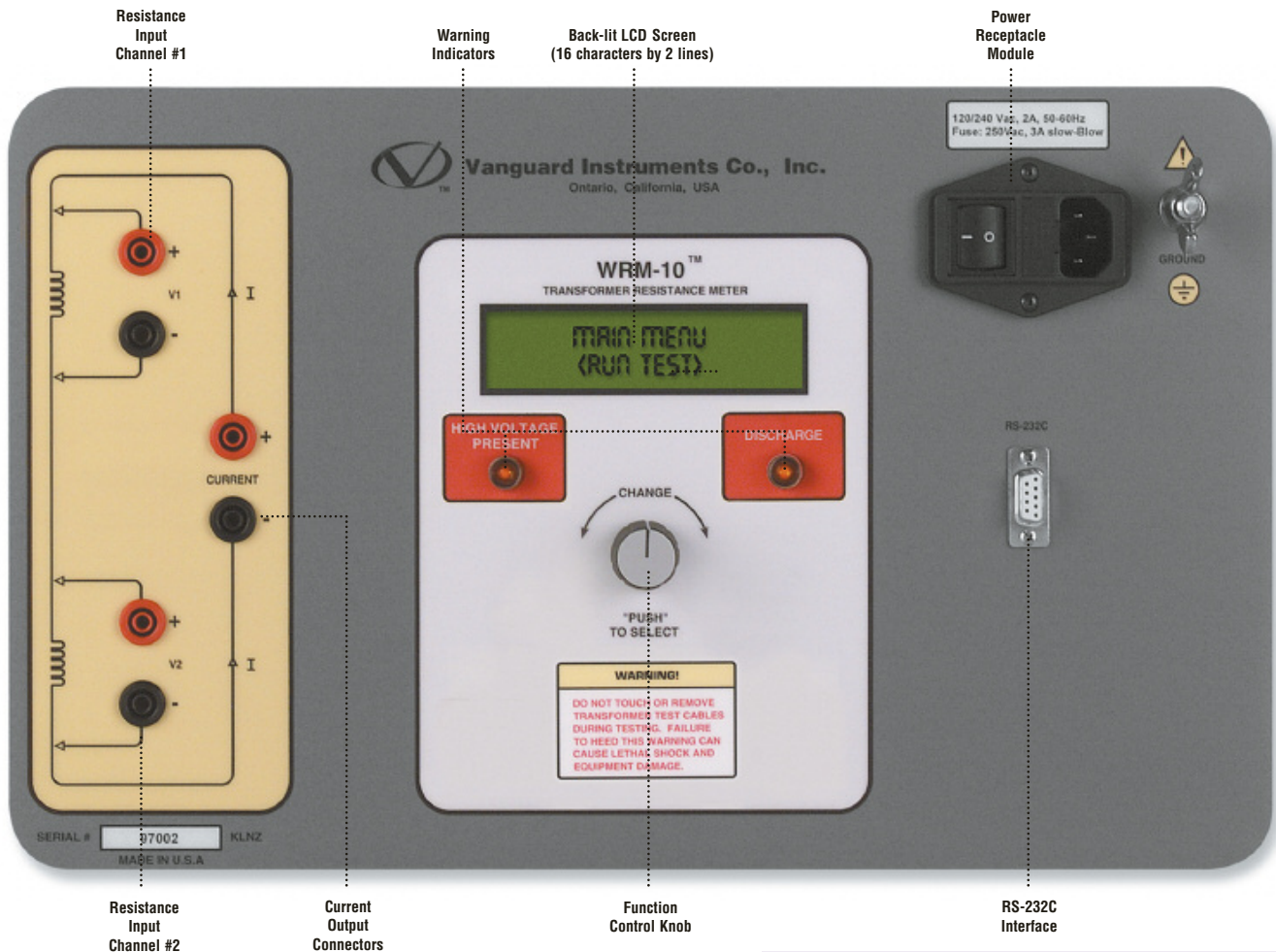

## FEATURES

- Auto discharge circuit for operator safety
- Auto current ranging from 10 mA to 10 A
- Digital resistance reading from 1 micro-ohm to 2,000 ohms
- Weighs 27 lbs (12.2 Kg)

## Ordering Information

WRM-10™ Winding Resistance Meter

WRM-10™, Cable	Part No: WRM-10
WRM-10™ Shipping Case	Part No: WRM-10 Case
50-ft Test Cable	Part No: WRM Test Cable



### **Vanguard Instruments Company, Inc.**

Vanguard Instruments Co., (VIC), was founded in 1991. Currently, our 28,000 square-foot facility houses Administration, Design & Engineering, and Manufacturing operations. From its inception, VIC's vision was, and is to develop and manufacture innovative test equipment for use in testing substation EHV circuit breakers and other electrical apparatus.

The first VIC product was a computerized circuit-breaker analyzer, which was a resounding success. It became the forerunner of an entire series of circuit-breaker test equipment. Since its beginning, VIC's product line has expanded to include microcomputer-based, precision micro-ohmmeters, single and three-phase transformer winding turns-ratio testers, winding-resistance meters, transformer tap-changing controllers, megaohm resistance meters, and a variety of other electrical utility maintenance support products.

VIC's performance-oriented products are well suited for the utility industry. They are rugged, reliable, accurate, user friendly, and most are computer controlled. Computer control, with innovative programming, provides many automated testing functions. VIC's instruments eliminate tedious and time-consuming operations, while providing fast, complex, test-result calculations. Errors are reduced and the need to memorize long sequences of procedural steps is eliminated. Every VIC instrument is competitively priced and is covered by a liberal warranty.

**Vanguard products are available from:**



**Vanguard Instruments Company, Inc.**

1520 S. Hellman Ave. • Ontario, California 91761 USA • P 909-923-9390 • F 909-923-9391  
[www.vanguard-instruments.com](http://www.vanguard-instruments.com)